

Period Style Bench/Chest - Simple Method

Tools & Materials

- Hammer + Finishing Nails
- Saw
- Ruler
- Wood Glue
- Sandpaper 60# and 120#
- 12ft Pine board 1"x12"
- Leather for hinge/straps?

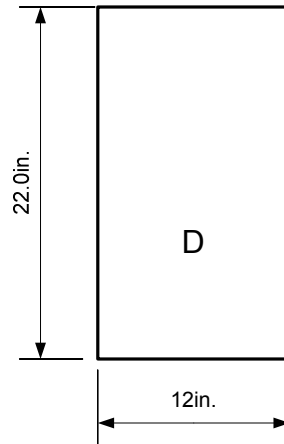
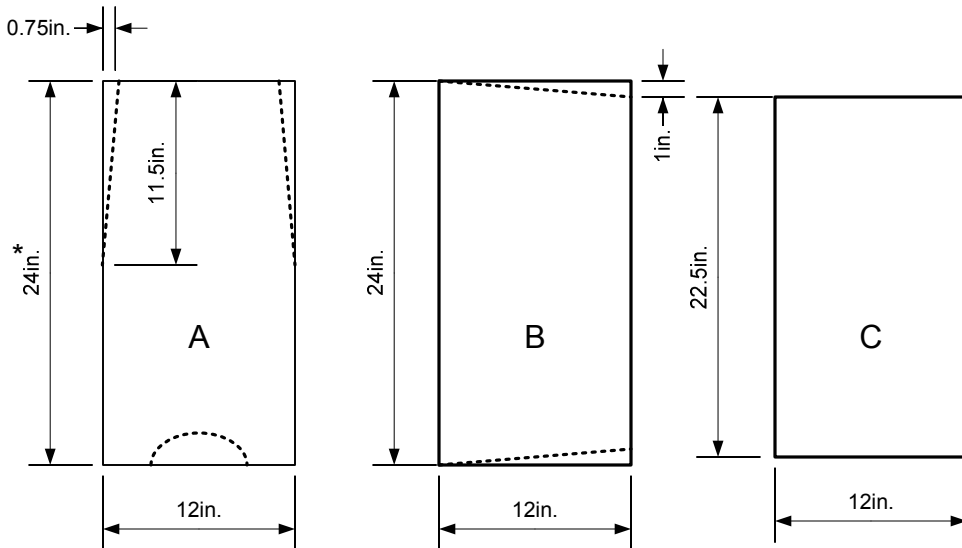

Cutting Instructions

1. Measure a comfortable chair or stool height [18-24" high usually] and note that number.
2. Measure & Cut 2 leg panels [Piece A] but use YOUR number from Step 1 instead of 24in. to make a custom fit for you.
3. Measure & Cut 2 side panels [Piece B], 1 bottom panel [Piece C], and 1 top panel [Piece D]
4. Cut slants as shown on both A's and B's [curve on A optional]
5. Sand all edges smooth

Assembly Instructions

6. Use glue between every wood joint
7. Glue/Nail both legs [A] to edges of 1 side [B]
8. G/N other side [B] to both legs
9. Fit bottom [C] in and Glue/Nail through sides and legs
- 10 DO NOT Glue/Nail lid! Use leather hinge or scraps to keep from sliding [See Diagram 3]

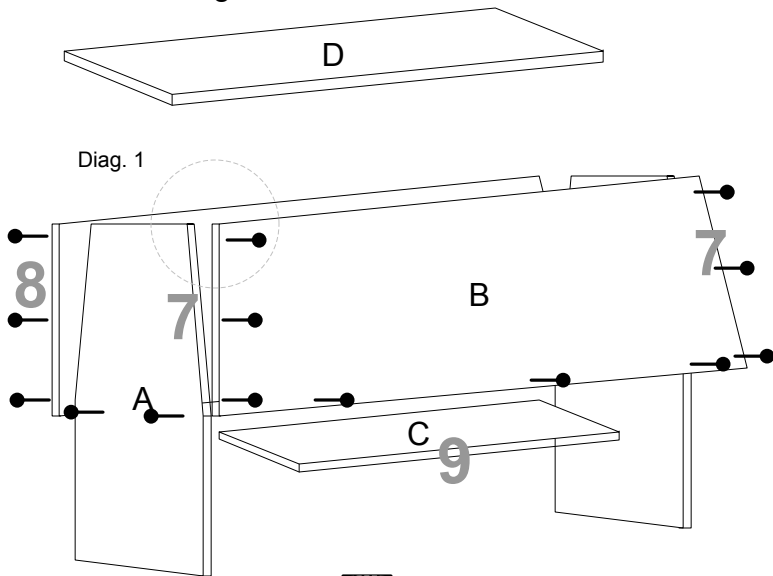

Notes

- 12" wide boards are REALLY 11.5" wide... ignore that and worry about LENGTH measurements
- Measure all cut angles from the EDGE INWARDS as drawn

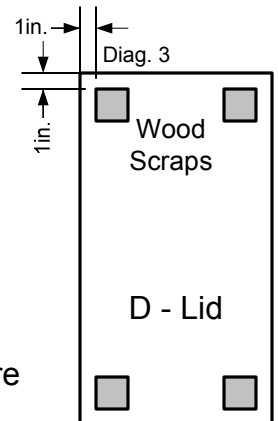

Diag. 2 - Joint Details - Top View

